



High Pressure Gate Valve

with pressure-seal bonnet

10/4002

PN 100-400, Class 600-2500

Design and Connections

- Forged, welded body, rising stem
- Butt weld ends acc. DIN3239 / ASME B16.25 / EN12627
- Flanges on request acc. DIN2501 / ASME B16.5
- Face to Face acc. DIN3202 / ASME B16.10 / EN558-1
- Rating acc. DIN2401 / ASME B16.34
- Testing acc. EN12266 / API 598

Mounting

- Installation preferably with stem vertically upwards
- Other installation positions on request
- Only for ON – OFF – function, not suitable for throttling function

Application

- Suitable for water, steam and other non-aggressive media

Options

- Release channel in wedge, single – side tight closure
- Over – pressure safety device
- Power – supply actuator
- By-pass
- Seat faced with stellite

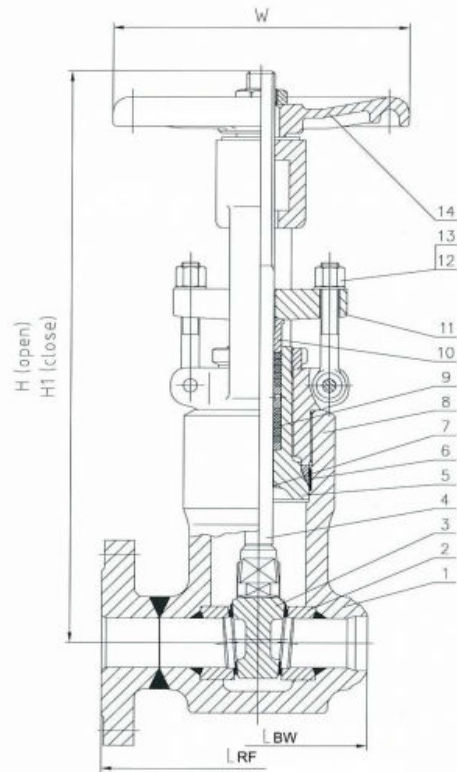



High Pressure Gate Valve

with pressure-seal bonnet

10/4002

PN 100-400, Class 600-2500

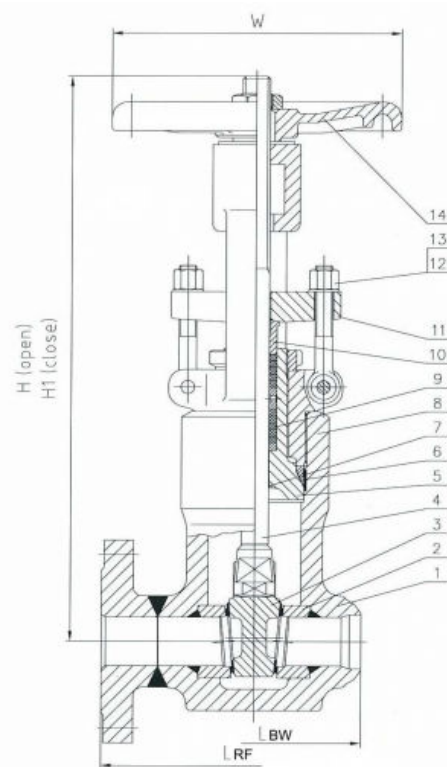

4 - Gate Valves

4 - Gate Valves

Werkstoffe							
Temperature range		up to 425°C	up to 470°C	up to 595°C	up to 595°C	up to 425°C	up to 595°C
Pos.	Designation	Mat. Set 1	Mat. Set 2	Mat. Set 3	Mat. Set 4	Mat. Set 5	special
1	Body	1.0460	1.5415	1.7335	1.7380	1.4404	1.4903
2	Seat ring	1.0460+HF	1.5415+HF	1.7335+HF	1.7380+HF	1.4404+HF	1.4903+HF
3	Wedge	1.0460+HF	1.5415+HF	1.7335+HF	1.7380+HF	1.4404+HF	1.4903+HF
4	Stem	1.4021	1.4021	1.4057	1.4057	1.4401	1.4057
5	Bonnet	1.0460	1.5415	1.7335	1.7380	1.4404	1.4903
6	Gasket	SS+r. Graphite	SS+r. Graphite	SS+r. Graphite	SS+r. Graphite	SS+r. Graphite	SS+r. Graphite
7	Back seat	Stellite	Stellite	Stellite	Stellite	Stellite	Stellite
8	Yoke	1.0619	1.7357	1.7357	1.7379	1.4408	1.7379
9	Stem packing	Grafit	Grafit	Grafit	Grafit	Grafit	Grafit
10	Gland	1.4021	1.4021	1.4057	1.4057	1.4401	1.4057
11	Gland flange	1.0619	1.5419	1.7357	1.7379	1.4408	1.7379
12	Gland eyebolt	Ck35	21CrMoV57	21CrMoV57	21CrMoV57	A2-70	21CrMoV57
13	Gland nut	C35	24CrMo5	24CrMo5	24CrMo5	A2-70	24CrMo5
14	Handwheel	Steel	Steel	Steel	Steel	Steel	Steel

HF ... Seat surfaces hardfaced



High Pressure Gate Valve

with pressure-seal bonnet

10/4002

PN 100-400, Class 600-2500

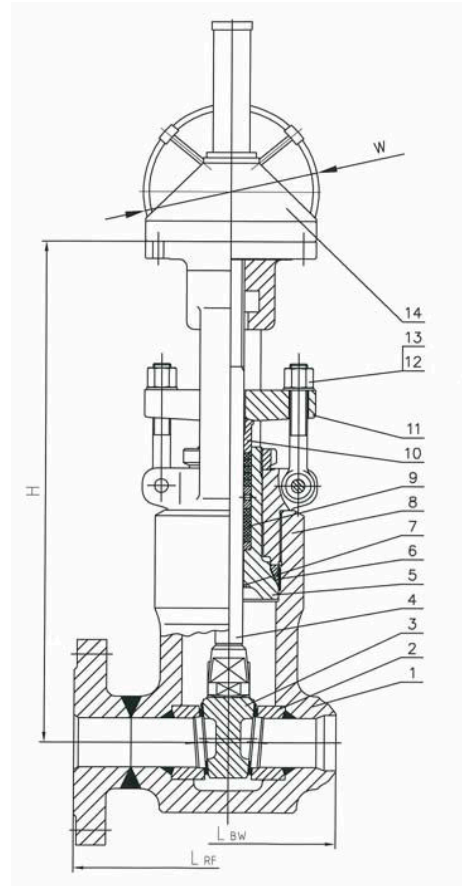
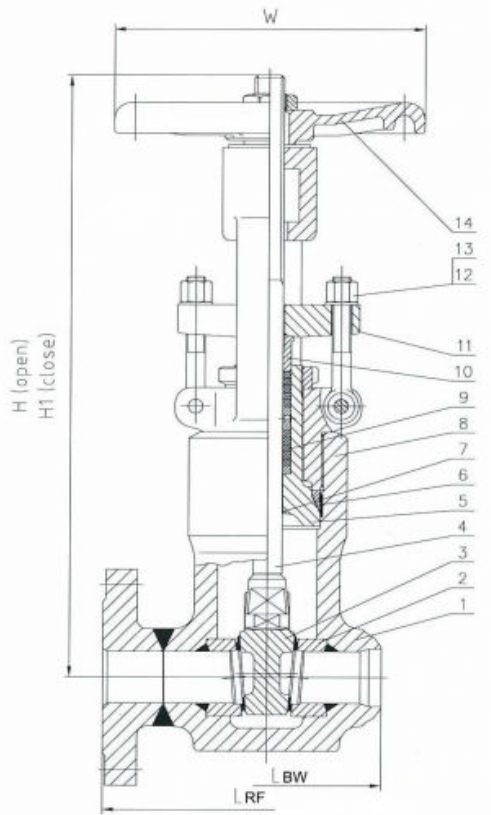

4 - Gate Valves

4 - Gate Valves

PN 100 - Class 600

DN	50 2"	65 2 1/2"	80 3"	100 4"	125 5"	150 6"	200 8"	250 10"	300 12"	350 14"	400 16"	450 18"	500 20"	600 24"
L BW/RF ¹	300	360	390	450	525	600	750	900	1050	1200	1350	-	1650	-
L BW ²	178	-	254	305	-	457	584	711	813	889	991	1092	1194	1397
L RF	292	-	356	432	-	559	660	787	838	889	991	1092	1194	1397
L RTJ	295	-	359	435	-	562	663	791	841	892	994	1095	1200	1407
W	200	200	250	400	500	500	600	700	-	-	-	-	-	-
H1	500	500	550	590	840	840	970	1160	1300	1500	1780	2000	2150	2400
H	550	560	630	690	990	990	1170	1410	1600	1850	2180	2450	2650	3000

¹) Face-to-Face acc. DIN-EN

²) Face-to-Face acc. ANSI-ASME



High Pressure Gate Valve

10/4002

with pressure-seal bonnet

PN 100-400, Class 600-2500

PN 160 - Class 900														
DN	50 2"	65 2 1/2"	80 3"	100 4"	125 5"	150 6"	200 8"	250 10"	300 12"	350 14"	400 16"	450 18"	500 20"	600 24"
L BW/RF ¹	300	360	390	450	525	600	750	900	1050	1200	1350	-	1650	-
L BW ²	216	-	305	356	-	508	660	787	914	991	1092	1143	1245	1397
L RF	368	-	381	457	-	610	737	838	965	1029	1130	1219	1321	1549
L RTJ	371	-	384	460	-	613	740	841	968	1038	1140	1232	1334	1568
W	250	200	300	400	500	500	-	-	-	-	-	-	-	-
H1	500	500	550	590	840	840	970	1250	1350	1580	1900	2050	2200	2500
H	550	560	620	690	990	990	1170	1500	1650	1930	2300	2600	2700	3100

PN 250 - Class 1500														
DN	50 2"	65 2 1/2"	80 3"	100 4"	125 5"	150 6"	200 8"	250 10"	300 12"	350 14"	400 16"	450 18"	500 20"	600 24"
L BW/RF ¹	300	360	390	450	525	600	750	900	1050	1200	1350	-	1650	-
L BW ²	216	-	305	406	-	559	711	864	991	1067	1194	1346	1473	1943
L RF	368	-	470	546	-	705	832	991	1130	1257	1384	1537	1664	1943
L RTJ	371	-	473	549	-	711	842	1000	1146	1276	1407	1559	1686	1972
W	250	200	400	600	-	-	-	-	-	-	-	-	-	-
H1	500	500	550	590	840	840	970	1250	1350	1780	2000	2200	2400	2600
H	550	560	630	690	990	990	1170	1500	1700	2130	2400	2650	2900	3200

PN 400 - Class 2500														
DN	50 2"	65 2 1/2"	80 3"	100 4"	125 5"	150 6"	200 8"	250 10"	300 12"	350 14"	400 16"	450 18"	500 20"	600 24"
L BW/RF ¹	300	360	390	450	525	600	750	900	1050	1200	1350	-	1650	-
L BW ²	279	-	368	457	-	610	762	914	1041	1118	1245	1397	1524	1676
L RF	451	-	578	673	-	914	1022	1270	1422	-	-	-	-	-
L RTJ	454	-	584	683	-	927	1038	1292	1445	-	-	-	-	-
W	300	200	500	700	-	-	-	-	-	-	-	-	-	-
H1	500	500	550	600	860	860	1000	1330	1480	1860	2090	2350	2650	2800
H	550	560	630	390	1010	1010	1200	1580	1780	2210	2490	2800	3150	3400

¹) Face-to-Face acc. DIN-EN

²) Face-to-Face acc. ANSI-ASME

4 - Gate Valves

4 - Gate Valves