



## Gate Valve

outside screw

10/114 - 10/116

Class 150-1500

- API standard 602
- Reduced & full port
- outside screw
- renewable seats
- socket welding, threaded, flanged or buttwelding ends

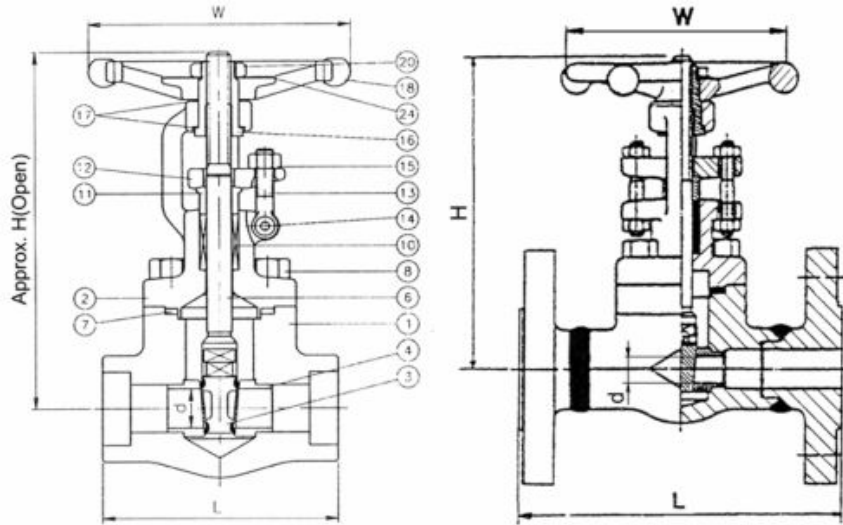

### Materials (ASTM Spezifikationen)

Pos.	Part Name	Materials (ASTM Spezifikationen)													
		A105	A182							A350					
1	Body	A105	F304	F304L	F316	F316L	F1	F5	F9	F11	F22	LF1	LF2	LF2	
2	Bonnet	A105	F304	F304L	F316	F316L	F1	F5	F9	F11	F22	LF1	LF2	LF2	
3	Wedge	A743 CA40	A315 CF8	A351 CF8M							A743 CA40				
4	Seat ring	A276 410	A276 304	A276 316							A276 410				
6	Stem	A276 410	A276 304	A276 316							A276 410				
7	Gasket	SS304	SS304 + PTFE							SS304 + asbestosfree					
8	Bolt	A193 B7	A193 B8							A193 B7	A320 L7				A193 B8
10	Packing	asbestosfree	asbestosfree							asbestosfree / Monel wire					
11	Gland	A276 410	A276 304							A276 410					
12	Gland flange	A105	A182 F304							A105					
13	Bolt	A276 304								A276 304					
14	Pin	A276 304								A276 304					
15	Nut	A194 2H	A194 8							A184 2H					
16	Stem nut	A276 410								A276 410					
17	Sleeve washer	A276 410								A276 410					
18	Handwheel	A197								A197					
20	Handwheel nut	A108 1020								A108 1020					
24	Name plate	Aluminium								Aluminium					

4 - Gate Valves

4 - Gate Valves



## Gate Valve

outside screw

10/114 - 10/116

Class 150-1500

### Type 10/114

Class 800 - Port/Ends reduced										
Size	L		H		W		d		Weight	
NPS	mm	inch	mm	inch	mm	inch	mm	inch	kg	lb
1/4	80	3,15	153	6,02	100	3,94	8	0,31	1,8	4
3/8	80	3,15	153	6,02	100	3,91	10	0,39	1,8	4
1/2	80	3,15	153	6,02	100	3,94	13	0,51	1,8	4
3/4	88	3,47	153	6,02	100	3,94	13	0,51	2	4,4
1	108	4,25	188	7,4	120	4,72	18	0,71	3,3	7,3
1 1/4	120	4,72	239	9,41	150	5,91	29	1,14	5,9	13
1 1/2	120	4,81	239	9,41	150	5,91	29	1,14	5,9	13
2	138	5,43	269	10,59	180	7,09	37	1,45	9	19,8

Class 800 - Port/Ends full										
Size	L		H		W		d		Weight	
NPS	mm	inch	mm	inch	mm	inch	mm	inch	kg	lb
1/4	80	3,15	153	6,02	100	3,94	8	0,31	1,8	4
3/8	80	3,15	153	6,02	100	3,94	10	0,39	1,8	4
1/2	80	3,15	153	6,02	100	3,94	13	0,51	1,8	4
3/4	108	4,25	188	7,4	120	4,72	18	0,71	3,3	7,3
1	120	4,72	239	9,41	150	5,91	24	0,94	5,9	13
1 1/4	120	4,72	239	9,41	150	5,91	29	1,14	5,9	13
1 1/2	138	5,43	269	10,59	180	7,09	37	1,45	9	19,8
2	220	8,66	313	12,32	210	8,27	46	1,81	15,5	34,2

### Type 10/115

Class 900/1500 - Port/Ends reduced										
Size	L		H		W		d		Weight	
NPS	mm	inch	mm	inch	mm	inch	mm	inch	kg	lb
1/4	108	4,25	188	7,4	120	4,72	8	0,31	3,5	7,7
3/8	108	4,25	188	7,4	120	4,72	10	0,39	3,5	7,7
1/2	108	4,25	188	7,4	120	4,72	13	0,51	3,5	7,7
3/4	108	4,25	188	7,4	120	4,72	13	0,51	3,5	7,7
1	120	4,72	239	9,41	150	5,91	18	0,71	6,2	13,7
1 1/4	120	4,72	239	9,41	150	5,91	29	1,14	6,2	13,7
1 1/2	138	5,43	269	10,59	180	7,09	29	1,14	9,5	20,9
2	220	8,66	313	12,32	210	8,27	37	1,45	16	35,3

4 - Gate Valves

4 - Gate Valves



## Gate Valve

outside screw

10/114 - 10/116

Class 150-1500

Class 900/1500 - Port/Ends full										
Size	L		H		W		d		Weight	
NPS	mm	inch	mm	inch	mm	inch	mm	inch	kg	lb
1/4	108	4,25	188	7,4	120	4,72	8	0,31	3,5	7,7
3/8	108	4,25	188	7,4	120	4,72	10	0,39	3,5	7,7
1/2	108	4,25	188	7,4	120	4,72	13	0,51	3,5	7,7
3/4	120	4,72	239	9,51	150	2,91	18	0,71	6,2	13,9
1	120	4,72	239	9,41	150	5,91	24	0,94	6,2	13,7
1 1/4	138	5,43	269	10,59	180	7,09	29	1,14	9,5	20,9
1 1/2	220	8,66	313	12,32	210	8,27	37	1,45	16	35,3

### 10/116

Class 150 - welded flange										
Size	L		H		W		d		Weight	
NPS	mm	inch	mm	inch	mm	inch	mm	inch	kg	lb
1/2	108	4,25	166	6,53	100	3,93	10	0,39	4,5	9,9
3/4	117	4,6	169	6,65	100	3,93	13,6	0,53	5,2	11,44
1	127	5	193	7,59	125	4,92	18	0,7	5,2	11,44
1 1/4	140	5,51	230	9,05	160	6,29	24	0,94	11,5	25,3
1 1/2	165	6,49	246	9,68	160	6,29	29	1,14	12,5	27,5
2	178	7,01	290	11,41	180	7,08	36,8	1,44	20,3	44,66

Class 300 - welded flange										
Size	L		H		W		d		Weight	
NPS	mm	inch	mm	inch	mm	inch	mm	inch	kg	lb
1/2	140	5,51	166	6,53	100	3,93	10	0,39	4,8	10,6
3/4	152	5,98	169	6,65	100	3,93	13,6	0,53	6,2	13,7
1	165	6,49	193	7,59	125	4,92	18	0,9	9,3	20,5
1 1/4	178	7,01	230	9,05	160	6,29	24	0,94	14	30,9
1 1/2	190	7,49	246	9,68	160	6,29	29	1,14	15,5	34,2
2	216	8,5	290	11,41	180	7,08	36,8	1,44	23,4	51,6

Class 600 - welded flange										
Size	L		H		W		d		Weight	
NPS	mm	inch	mm	inch	mm	inch	mm	inch	kg	lb
1/2	165	6,49	166	6,53	100	3,93	10	0,39	5,9	13,0
3/4	190	7,48	169	6,65	100	3,93	13,6	0,53	7,4	16,3
1	216	8,5	193	7,59	125	4,92	18	0,7	10,4	22,9
1 1/4	229	9,01	230	9,05	160	6,29	24	0,94	16,2	35,7
1 1/2	241	9,48	156	9,68	160	6,29	29	1,14	17,5	38,6
2	292	11,49	290	11,41	180	7,08	36,8	1,44	28,3	62,4

4 - Gate Valves

4 - Gate Valves