

## standard features

- **Description** PRESSURE SEAL COVER  
FULL OPENING  
LAPPED DISC AND SEAT  
WELDED IN SEATS
- **Design** DIN 3352  
DIN 3840
- **Face to face** DIN 3202
- **Flanges** DIN 2501  
DIN 2547  
DIN 2526 FORM E  
BW TO DIN 3239
- **Testing** DIN 3352 Part 1  
DIN 3230 Part 3
- **Rating** DIN 2401
- **Marking** EN 19  
CE - PED
- **Certificates** EN 10204 – 3.1 B

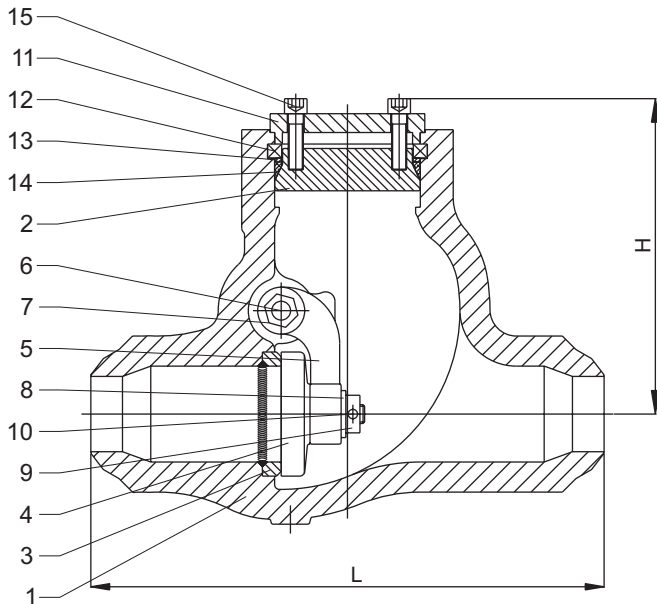

PART NAME	SET 1	SET 2
1 Body	1.0619	1.4581
2 Cover	1.0619	1.4581
3 Ring - seat surface	1.0460 + HF (1)	X2CrNiMo17-12-2 + HF (1)
4 Disc - seat surfaces	1.0619 + HF (2)	1.4581 + HF (2)
5 Hinge	1.0619	1.4581
6 Hinge pin	X20Cr13	X5CrNiMo17-12-2
7 Plug (externally)	1.0460	X5CrNiMo17-12-2
8 Plate	1.0460	X5CrNiMo17-12-2
9 Nut	C35	A2-70
10 Pin	X5CrNiMo17-12-2	X5CrNiMo17-12-2
11 Retainer flange	1.0460	1.4401
12 Segmented retainer ring	X20Cr13	1.4401
13 Spacer ring	X20Cr13	1.4401
14 Gasket	S. S. reinforced graphite (3)	S. S. reinforced graphite (3)
15 Bolt	CK35	A2-70

- (1) On request: faced with Stellite® - Monel® - Hastelloy® - other materials  
 (2) On request: faced with Stellite® - Monel® - Hastelloy® - other materials  
 (3) On request: Soft iron - Stainless steel



## PRESSURE SEAL SWING CHECK VALVES DIN PN 100 - F2

SIZE	50	65	80	100	125	150	200	250	300	350	400	500	600
L BW	300	340	380	430	500	550	650	775	900	1025	1150	1275	1600
L RF	300	340	380	430	500	550	650	775	900	1025	1150	1275	1600
H	180	205	215	275	300	350	390	450	500	555	630	800	1000

## PRESSURE SEAL SWING CHECK VALVES DIN PN 160 - F8

SIZE	50	65	80	100	125	150	200	250	300	350	400	500	600
L BW	300	360	390	450	525	600	750	900	1050	1200	1350	1650	--
L RF	300	360	390	450	525	600	750	900	1050	1200	1350	1650	--
H	245	260	250	310	340	390	510	580	620	680	740	850	--

## PRESSURE SEAL SWING CHECK VALVES DIN PN 250 - F9

SIZE	50	65	80	100	125	150	200	250	300	350	400	500	600
L BW	350	425	470	550	650	750	950	1150	1350	1550	1750	--	--
L RF	350	425	470	550	650	750	950	1150	1350	1550	1750	--	--
H	245	270	290	350	380	420	630	690	750	800	980	--	--

## PRESSURE SEAL SWING CHECK VALVES DIN PN 320 - F9

SIZE	50	65	80	100	125	150	200	250	300	350	400	500	600
L BW	350	425	470	550	650	750	950	1150	1350	1550	1750	--	--
L RF	350	425	470	550	650	750	950	1150	1350	1550	1750	--	--
H	245	280	300	380	405	430	650	720	780	--	--	--	--

## PRESSURE SEAL SWING CHECK VALVES DIN PN 420 - F9

SIZE	50	65	80	100	125	150	200	250	300	350	400	500	600
L BW	350	425	470	550	650	750	950	1150	1350	1550	1750	--	--
L RF	350	425	470	550	650	750	950	1150	1350	1550	1750	--	--
H	245	280	300	380	405	430	650	720	780	--	--	--	--

All dimensions in mm (except where differently indicated)

### *features on request*

- DISC WITH PTFE OR RUBBER
- INTEGRAL SEAT
- BY-PASS
- DRAIN PLUG
- FLANGED ENDS
- RTJ FLANGES
- ANSI CONNECTIONS

